



PHOENIX

FOR HANDLING  
2022/23

**#DesignedForLife**

**FOR HANDLING  
2022/23**

# FOR DESIGNED LIFE

## Phoenix lives for you.

Our **purpose** is to make every moment of your life **practical, smart, seamless** and **beautiful**. We imagine, create and manufacture **products** envisioning what can give you the **most trust, comfort** and **support** - everything you would look for in a life partner!

**Look around, and you'll see we're right there with you. We are a part of your life - we design for life.**



# THE CIRCULAR STORY

At Phoenix, we have over twelve years of experience in creating **functional, practical and sustainable solutions** for all your **Handling** needs. Our crates recycling process is **zero-waste, cost-effective,** and **hassle-free.**

We collect your damaged crates, crush and sanitize them to build new ones. These newly recycled crates are given back **LIFE.** The process of breaking down your old crates requires a lot less energy than creating new ones from scratch. Our expertise allows us to fulfil your industrial orders with proficiency, whether you desire stackable, nestable, or bright colored crates.

Your Handling needs, need not be not be short-lived or crowd landfills anymore. We are committed to protecting the environment and proud of our circular crates solution. Join us in minimizing waste without compromising on quality.

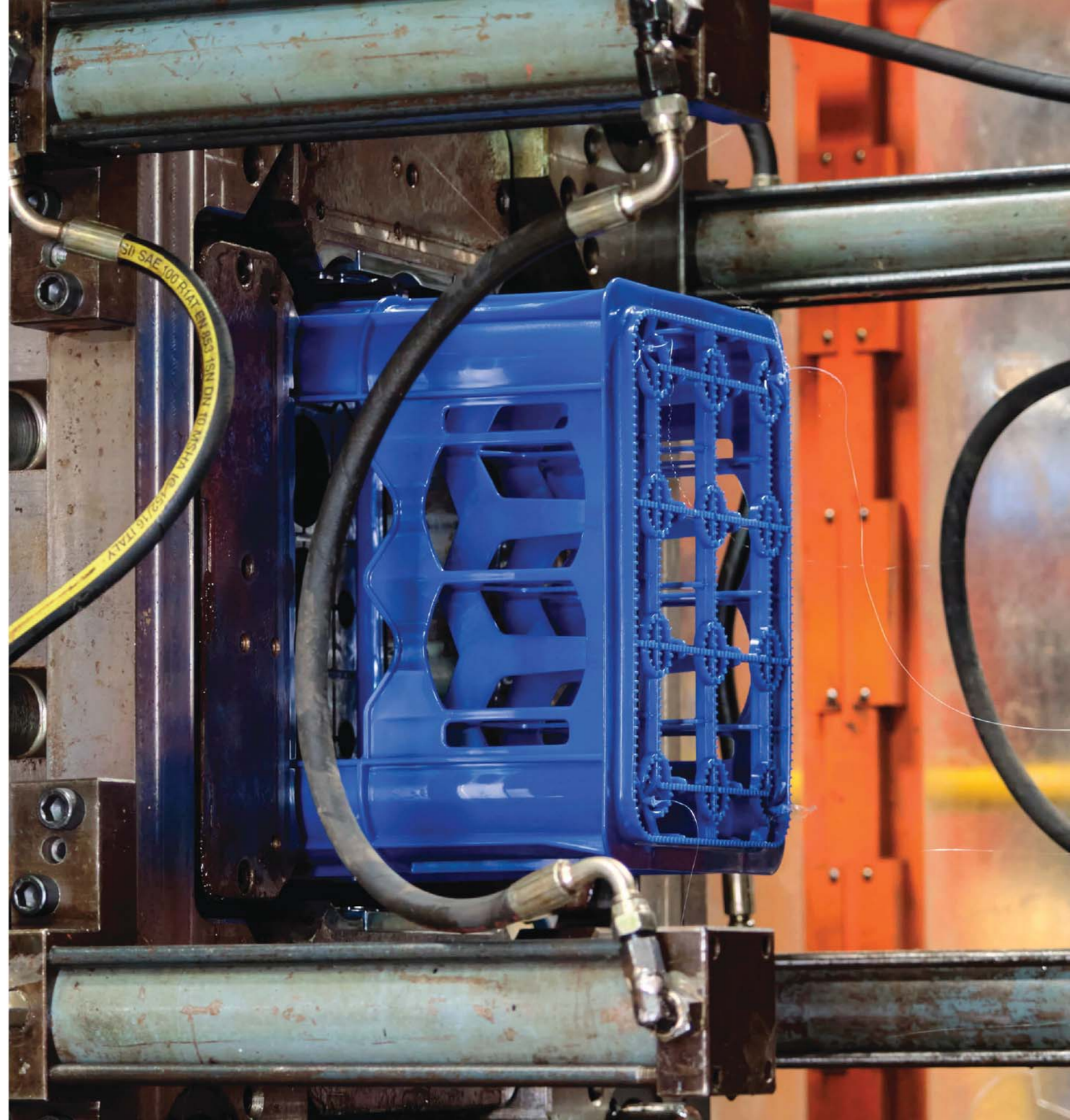

# OUR PURPOSE

The Phoenix Industrial **Crates & Pallets range** is specially **engineered** and **manufactured** for the purposes of convenient and **safe handling** of a wide range of goods. We carefully design our solutions to make your **LIFE** practical, smart, and seamless.

Our crates & pallets are most commonly used to improve **warehouse & logistic operations** in industries ranging from **Agriculture & Livestock**, **Food & Beverage**, and the **Marine** Industry.

We partner with our customers to provide **tailor-made**, end to end **sustainable & circular solutions** by collecting crates that have reached the end of their lives, and **re-processing** them into new and usable ones. This is a culmination of our dedicated engineering, and R&D teams coupled by our years of experience in **industry leadership**. We are on a journey of continuous improvement in this area. We believe we have scratched the surface and have a long way to go. **Join us!**





# CONTENT

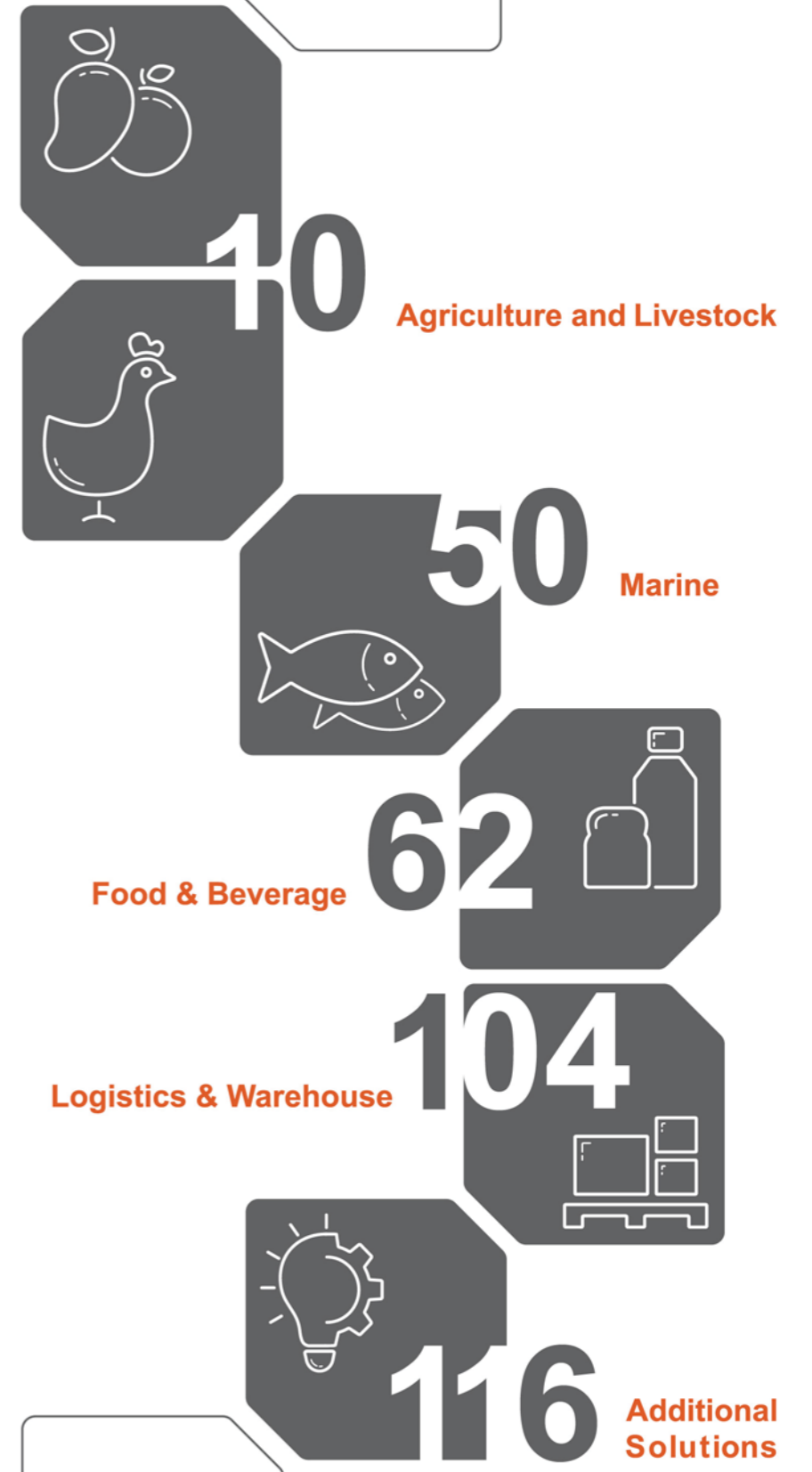



# AGRICULTURE AND LIVESTOCK

CRATE  
AC16

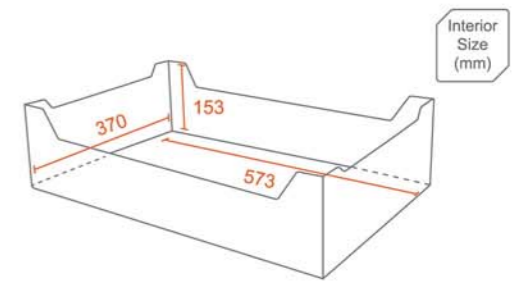
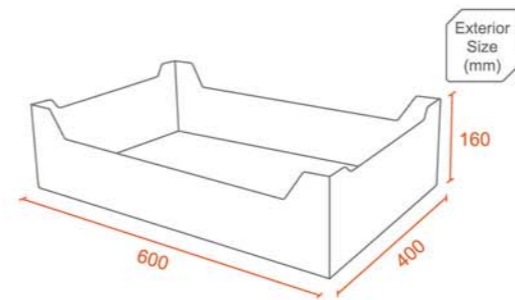

Crate Weight (Kg) 1.6	Crate Capacity (L) 32	Stackable ✓	Nestable ✗
Crate Load (Max) (Kg) 20	Stacking Units (Max) 10	Material Polyethylene	



CRATE  
AC23

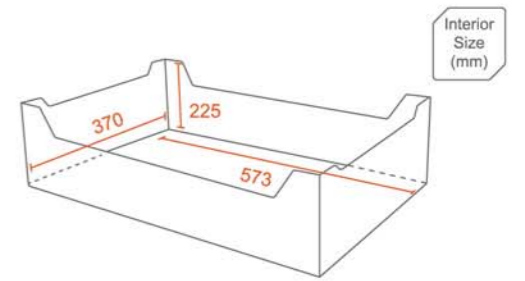
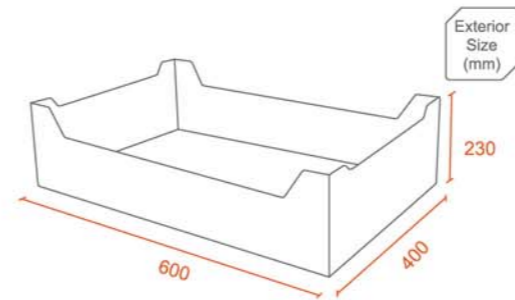
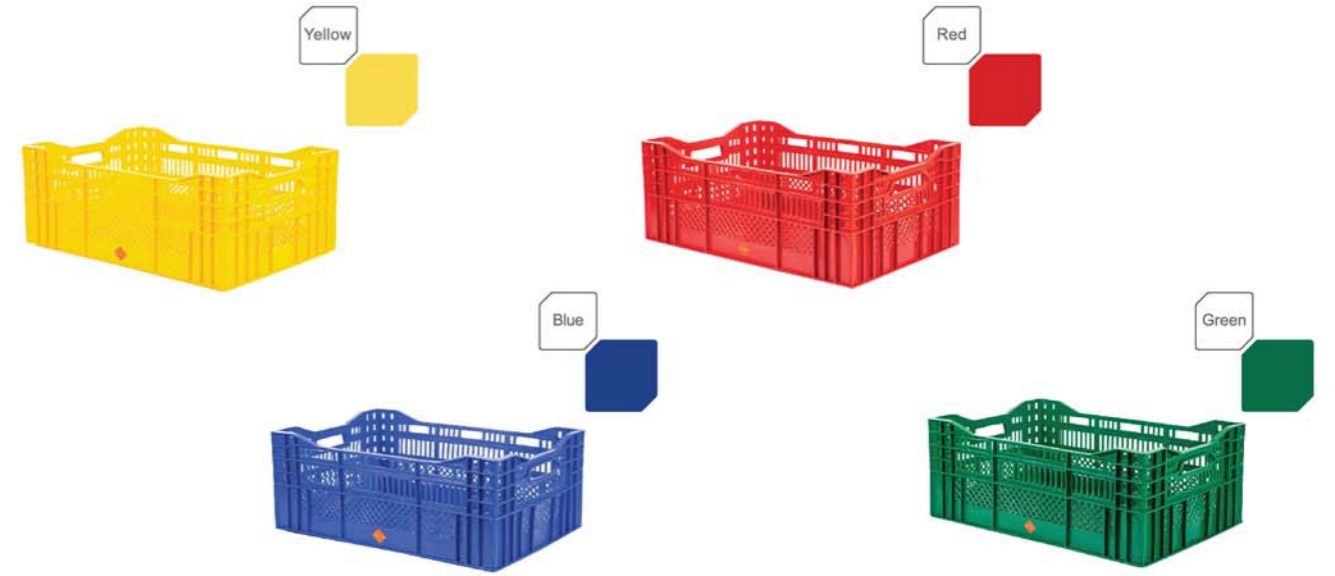

Crate Weight (Kg)	2	Crate Capacity (L)	48	Stackable	✓	Nestable	✗
Crate Load (Max) (Kg)	25	Stacking Units (Max)	6	Material	Polyethylene		

CRATE  
AC26

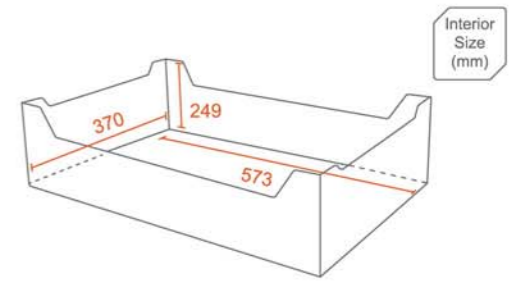
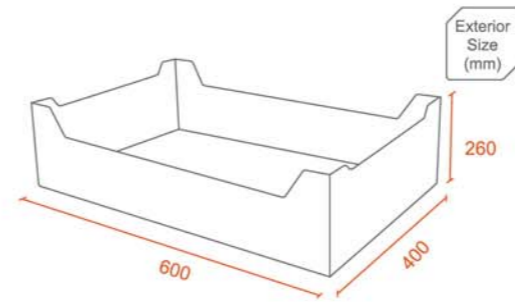

Crate Weight (Kg)	2.2	Crate Capacity (L)	52	Stackable	✓	Nestable	✗
Crate Load (Max) (Kg)	25	Stacking Units (Max)	6	Material	Polyethylene		

CRATE  
AC30

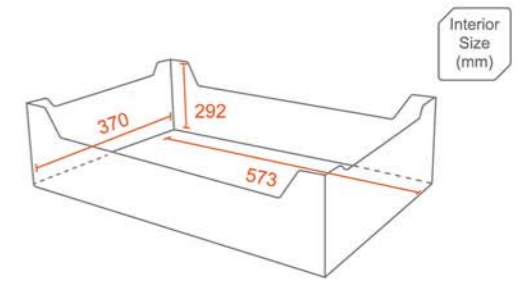
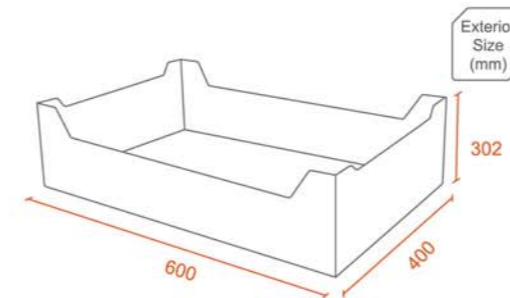

Crate Weight (Kg)  
2.3

Crate Capacity (L)  
62

Stackable  
✓

Nestable  
✗

Crate Load (Max) (Kg)  
25

Stacking Units (Max)  
6

Material  
Polyethylene



CRATE  
AC25

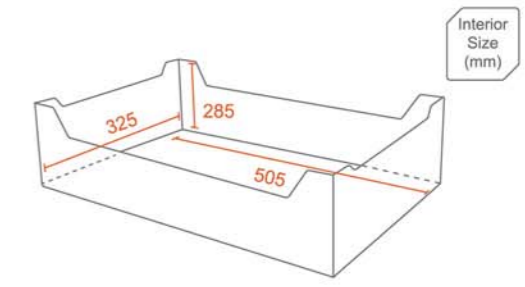
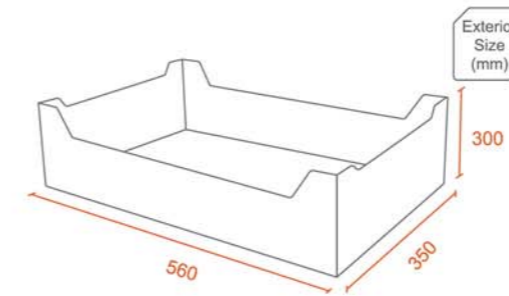

Crate Weight (Kg)  
1.7

Crate Capacity (L)  
48

Stackable  
✓

Nestable  
✗

Crate Load (Max) (Kg)  
20

Stacking Units (Max)  
6

Material  
Polypropylene

# CRATE AC15

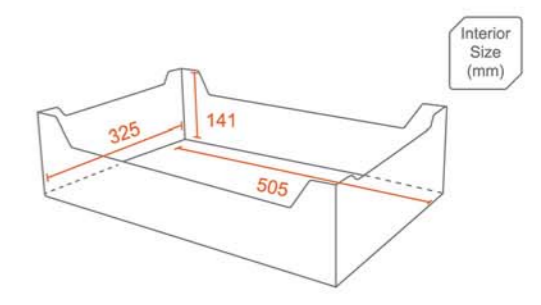
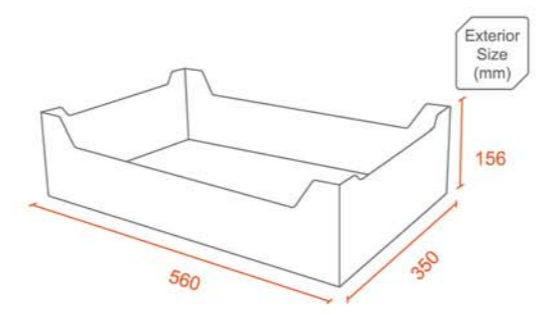

- Crate Weight (Kg) 1
- Crate Capacity (L) 23
- Stackable ✓
- Nestable ✗
- Crate Load (Max) (Kg) 15
- Stacking Units (Max) 8
- Material Polypropylene

CRATE  
AC29

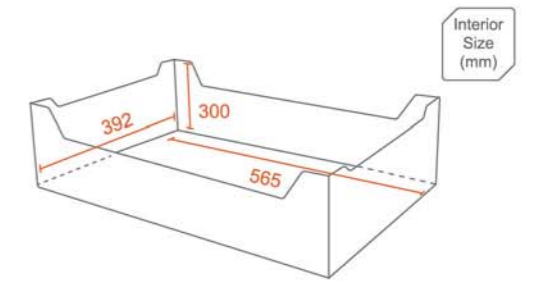
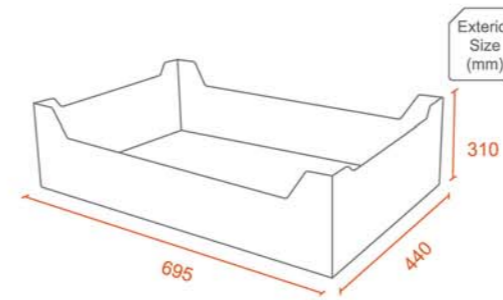

Crate Weight (Kg)

2

Crate Capacity (L)

67

Stackable

✓

Nestable

✓

Crate Load (Max) (Kg)

25

Stacking Units (Max)

6

Material

Polypropylene

CRATE  
AC50

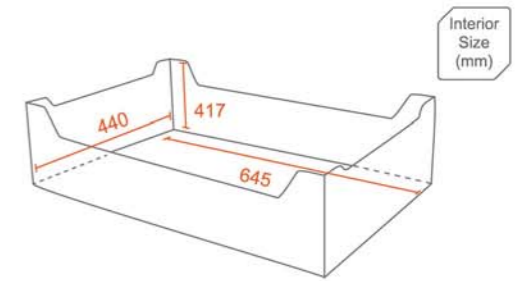
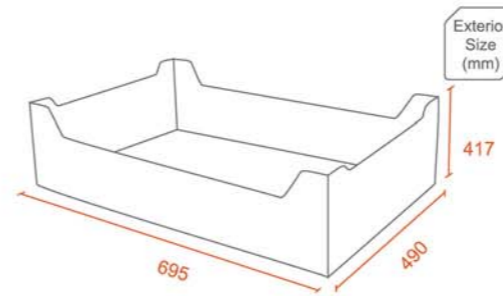

Crate Weight (Kg)

2.9

Crate Capacity (L)

113

Stackable



Nestable



Crate Load (Max) (Kg)

30

Stacking Units (Max)

4

Material

Polypropylene



EGG  
CRATE  
EC01

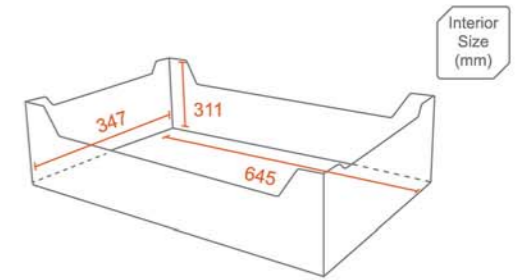
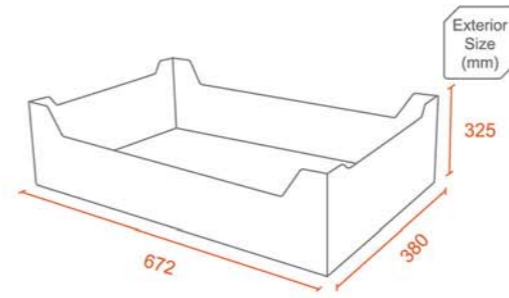

- Crate Weight (Kg) 2.1
- Crate Capacity (L) 70
- Stackable ✓
- Nestable ✗
- Crate Load (Max) (Kg) 20
- Stacking Units (Max) 6
- Material Polypropylene



EGG  
TRAY  
EC02

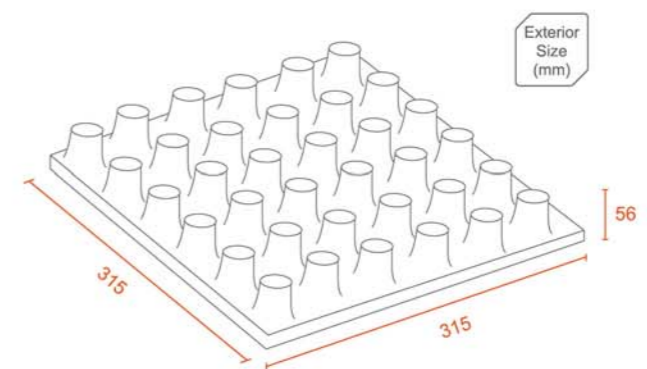
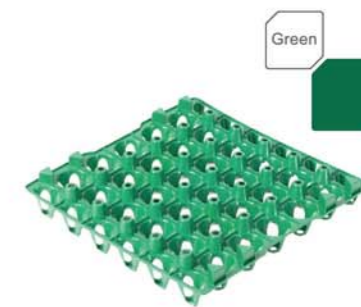
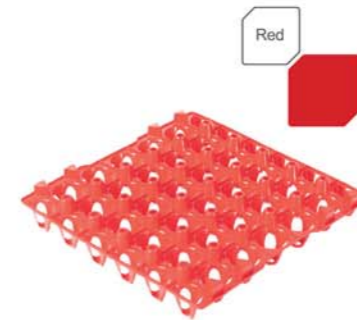
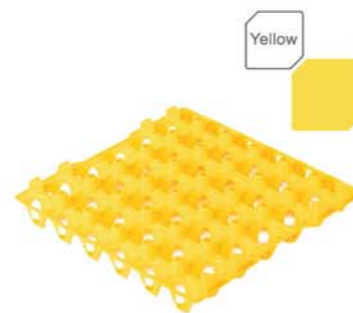

Crate Weight (Kg)  
0.2

Crate Capacity (Pcs)  
30

Stackable  
✓

Nestable  
✓

Stacking Units (Max) Dynamic Condition  
5

Stacking Units (Max) Static Condition  
10

Material  
Polypropylene

TOMATO CRATE TC01

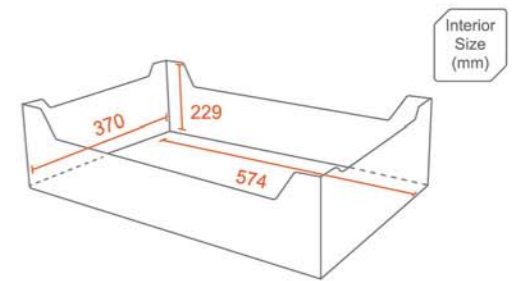
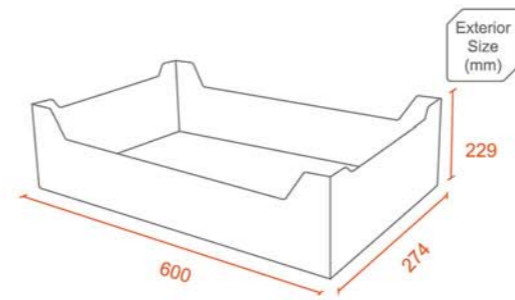
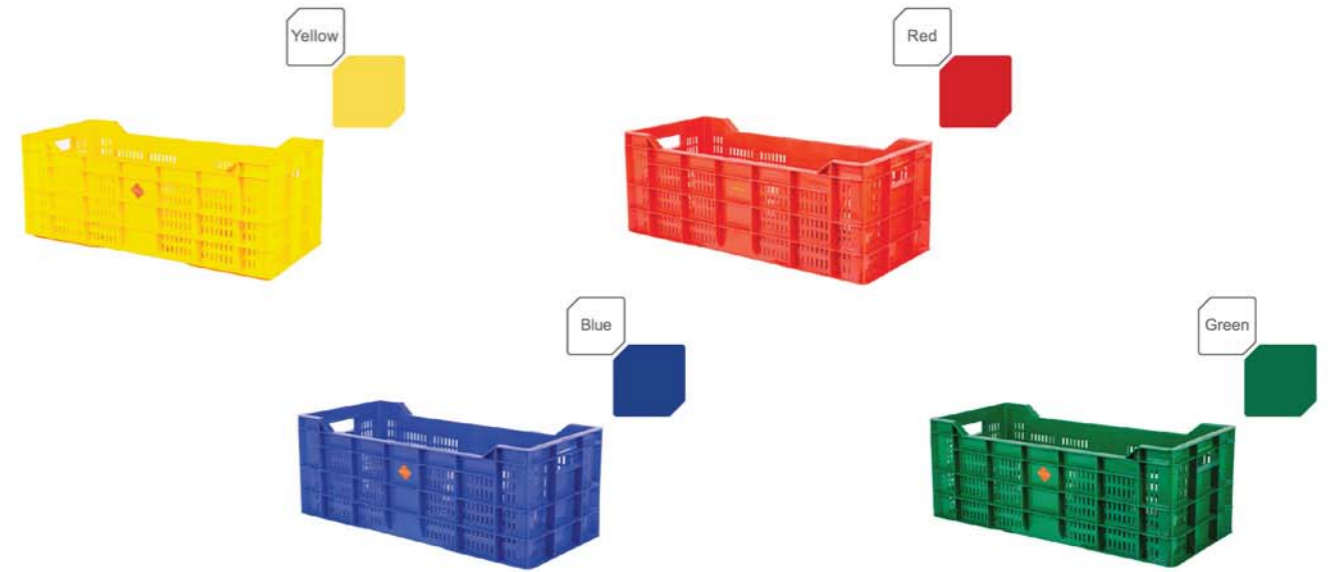

Crate Weight (Kg)	1.1	Crate Capacity (L)	49	Stackable	✓	Nestable	✗
Crate Load (Max) (Kg)	20	Stacking Units (Max)	6	Material	Polypropylene		

CRATE  
AC  
43170

Mini

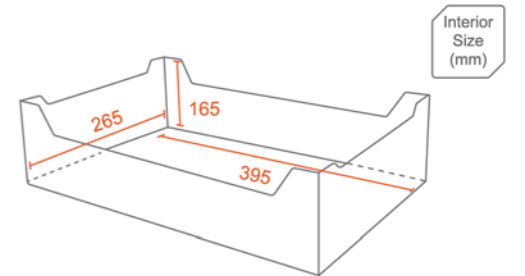
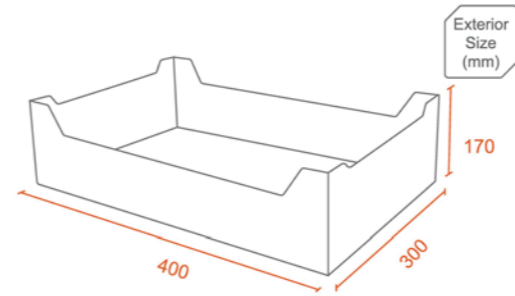

Crate Weight (Kg)

0.85

Crate Capacity (L)

17

Stackable

✓

Nestable

✓

Crate Load (Max) (Kg)

6

Stacking Units (Max)

14

Material

Polyethylene

CRATE  
AC  
64170

Small

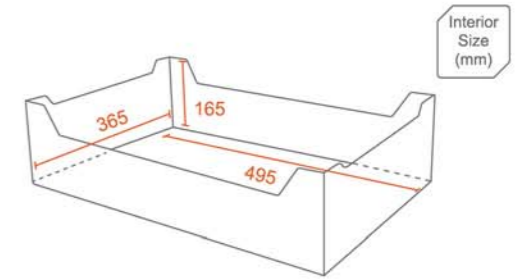
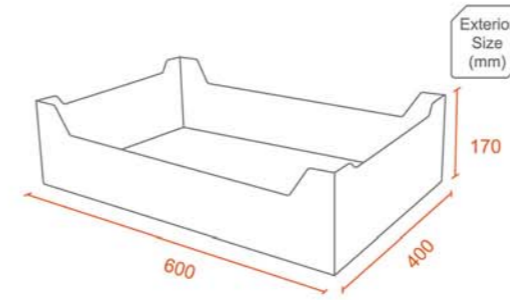

Crate Weight (Kg)

1.44

Crate Capacity (L)

30

Stackable

✓

Nestable

✓

Crate Load (Max) (Kg)

10.5

Stacking Units (Max)

12

Material

Polyethylene

CRATE  
AC  
64250

Large



Brown



Yellow

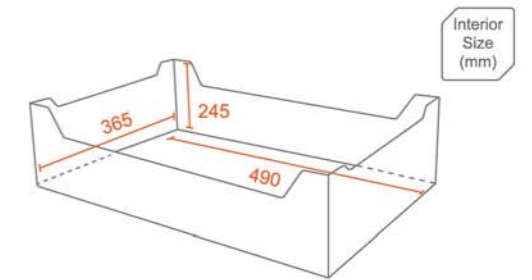
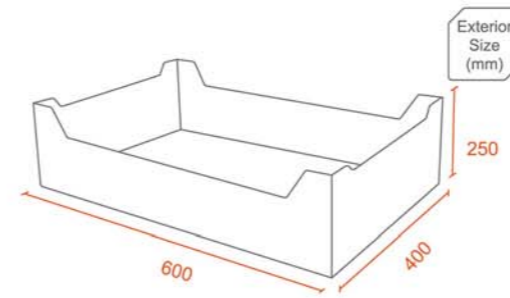

Crate Weight (Kg)

1.88

Crate Capacity (L)

44

Stackable

✓

Nestable

✓

Crate Load (Max) (Kg)

20

Stacking Units (Max)

7

Material

Polyethylene

POULTRY  
TRANSPORT  
CRATE

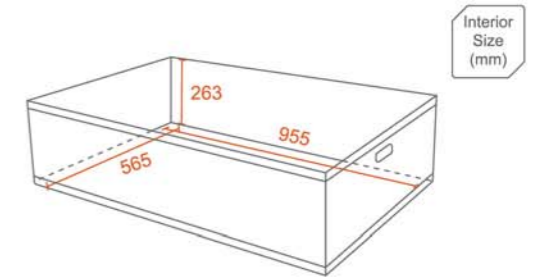
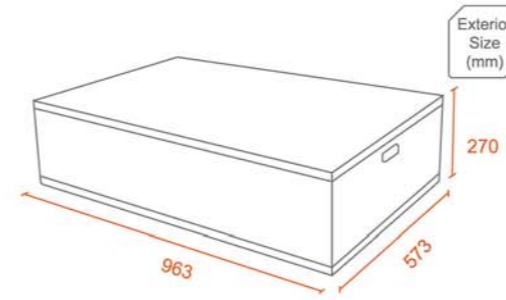

Crate Weight (Kg)

6.9

Crate Capacity (L)

142

Stackable

✓

Nestable

✗

Crate Load (Max) (Kg)

25

Stacking Units (Max)

8

Material

Polypropylene



FREEZER  
CRATE  
PC60

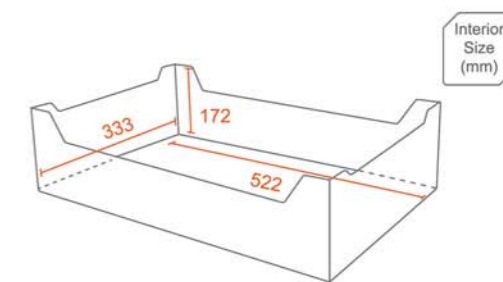
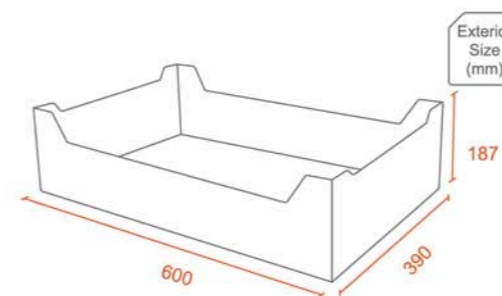

Crate Weight (Kg)	1.2	Crate Capacity (L)	25	Stackable	✓	Nestable	✓
Crate Load (Max) (Kg)	20	Stacking Units (Max)	8	Material	Polypropylene		

CRATE  
AC27

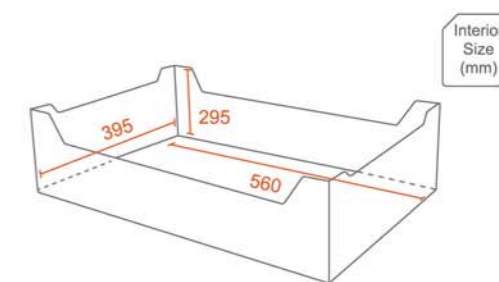
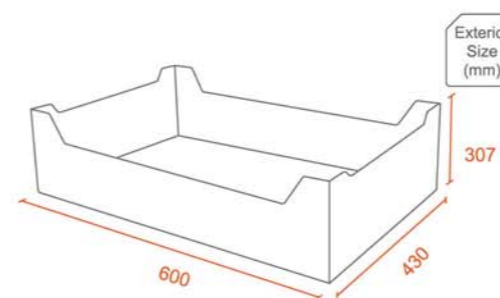

Crate Weight (Kg)	1.9	Crate Capacity (L)	65	Stackable	✓	Nestable	✓
Crate Load (Max) (Kg)	25	Stacking Units (Max)	6	Material	Polypropylene		

# MARINE



CRATE  
AC32

WITH  
LID



Yellow



Red



Blue



Green

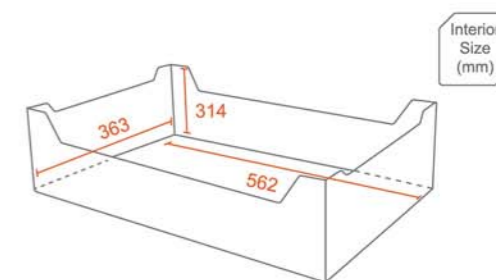
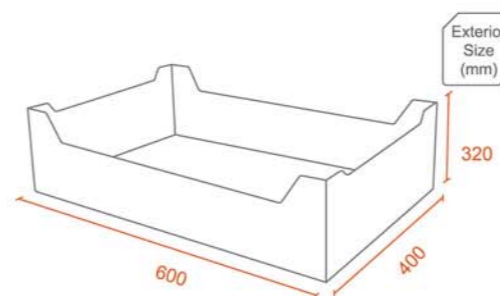

Crate Weight  
(with lid)  
(Kg)

2.95

Crate Capacity  
(L)

64

Stackable



Nestable



Crate Weight  
(without lid)  
(Kg)

2.45

Crate Load  
(Max) (Kg)

25

Stacking  
Units  
(Max)

6

Material

Polyethylene



මැරිනි

CRATE  
MC40

WITH  
LID

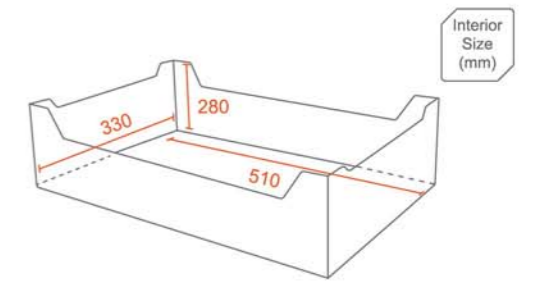
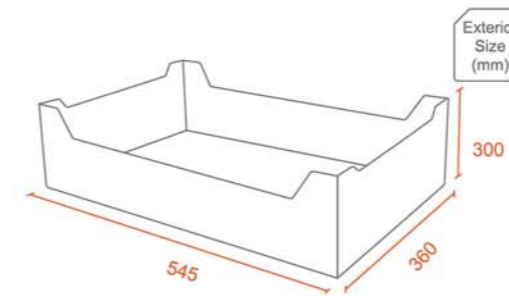

Crate Weight  
(with lid)  
(Kg)

2.67

Crate Capacity  
(L)

45

Stackable



Nestable



Crate Weight  
(without lid)  
(Kg)

2.13

Crate Load  
(Max) (Kg)

25

Stacking  
Units  
(Max)

6

Material

Polyethylene



CRATE  
MC41

WITH  
LID



Blue



Yellow

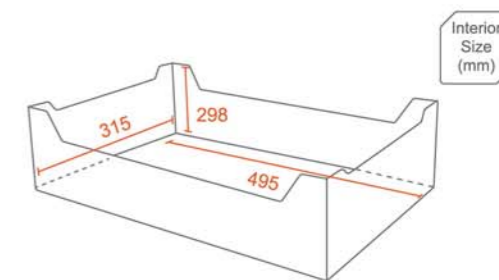
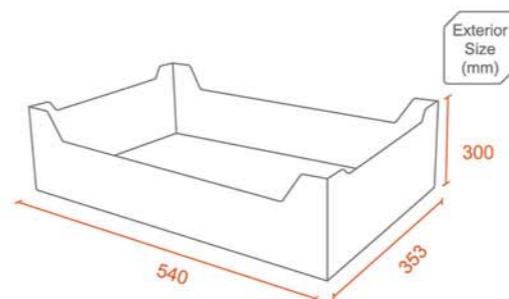

Crate Weight  
(with lid)  
(Kg)

2.1

Crate Capacity  
(L)

45

Stackable



Nestable



Crate Weight  
(without lid)  
(Kg)

1.6

Crate Load  
(Max) (Kg)

20

Stacking  
Units  
(Max)

6

Material

Polyethylene



# FOOD AND BEVERAGE



CRATE  
AC12

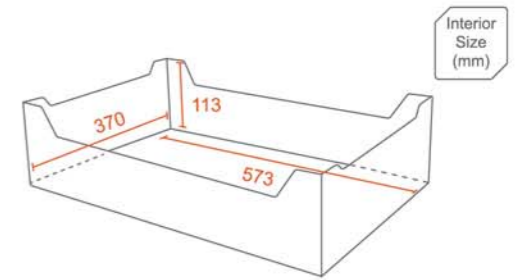
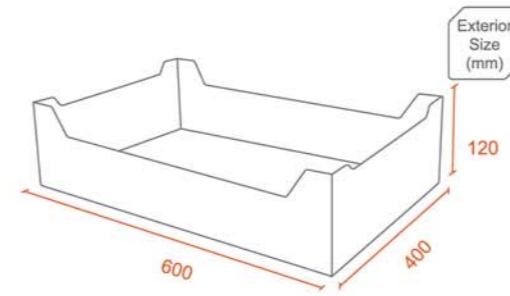

Crate Weight (Kg)

1.5

Crate Capacity (L)

24

Stackable

✓

Nestable

✗

Crate Load (Max) (Kg)

15

Stacking Units (Max)

10

Material

Polyethylene

CRATE  
AC12

FULLY  
COVERED  
WITH LID

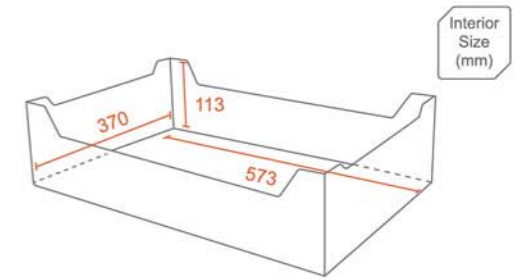
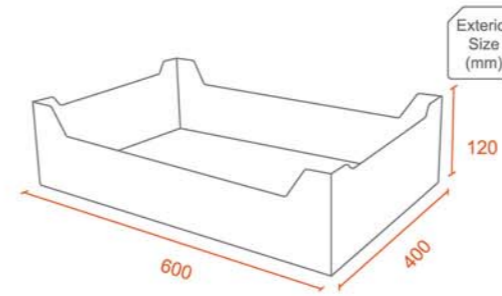
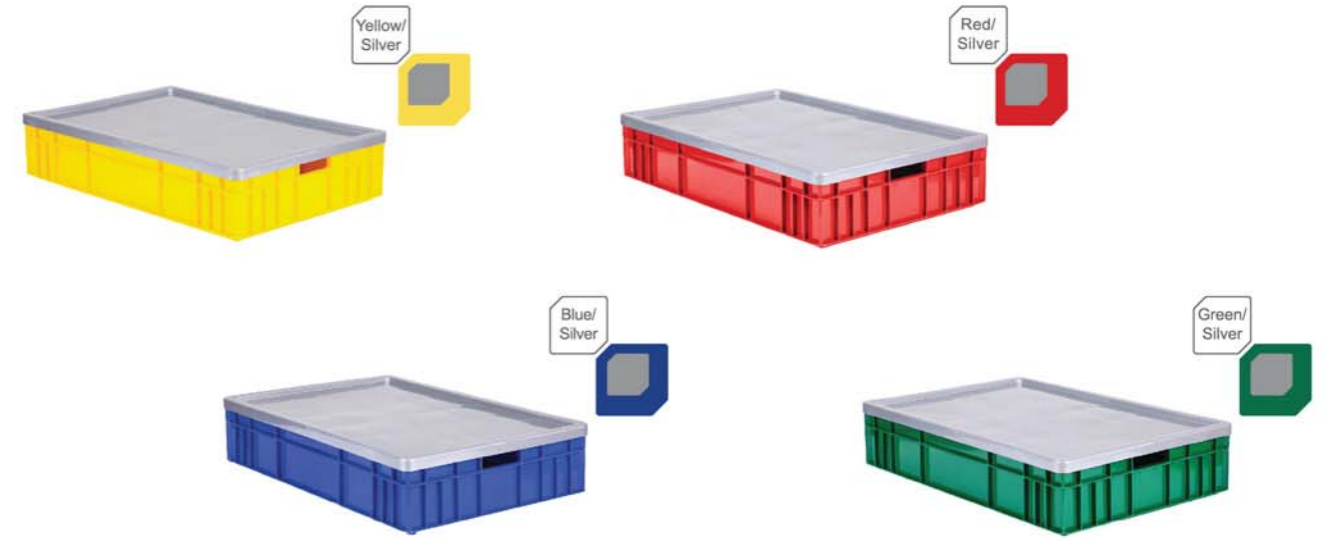

Crate Weight  
(with lid)  
(Kg)

2.4

Crate Capacity  
(L)

24

Stackable

✓

Nestable

✗

Crate Weight  
(without lid)  
(Kg)

1.8

Crate Load  
(Max) (Kg)

15

Stacking  
Units  
(Max)

10

Material

Polyethylene

# CRATE AC16

FULLY COVERED WITH LID

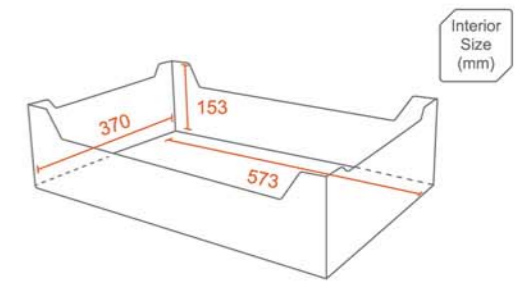
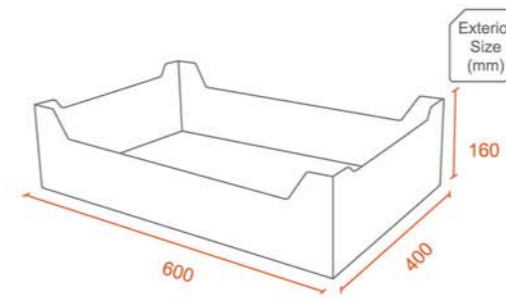

Crate Weight (with lid) (Kg)  
**2.5**

Crate Capacity (L)  
**32**

Stackable

Nestable

Crate Weight (without lid) (Kg)  
**1.95**

Crate Load (Max) (Kg)  
**20**

Stacking Units (Max)  
**10**

Material  
**Polyethylene**

CRATE  
MC14

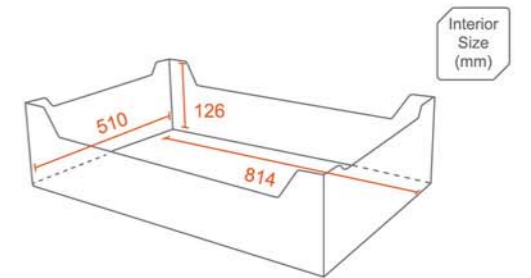
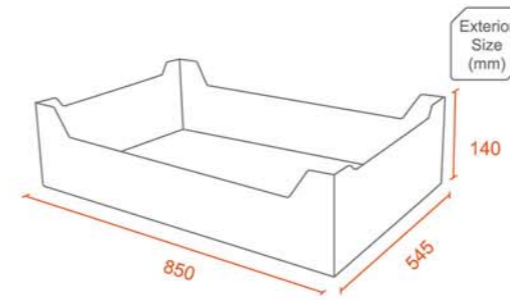

Crate Weight (Kg)	3.1	Crate Capacity (L)	52	Stackable	✓	Nestable	✗
Crate Load (Max) (Kg)	20	Stacking Units (Max)	8	Material	Polypropylene		

CRATE  
MC25

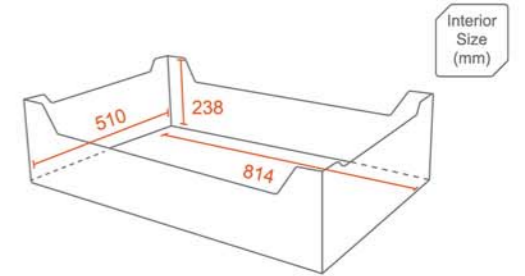
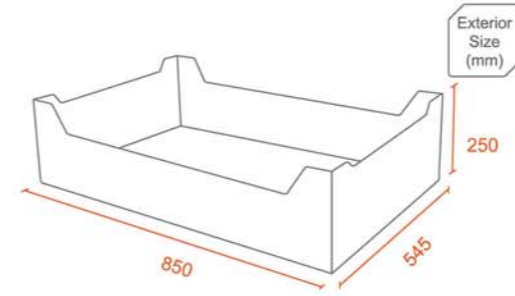
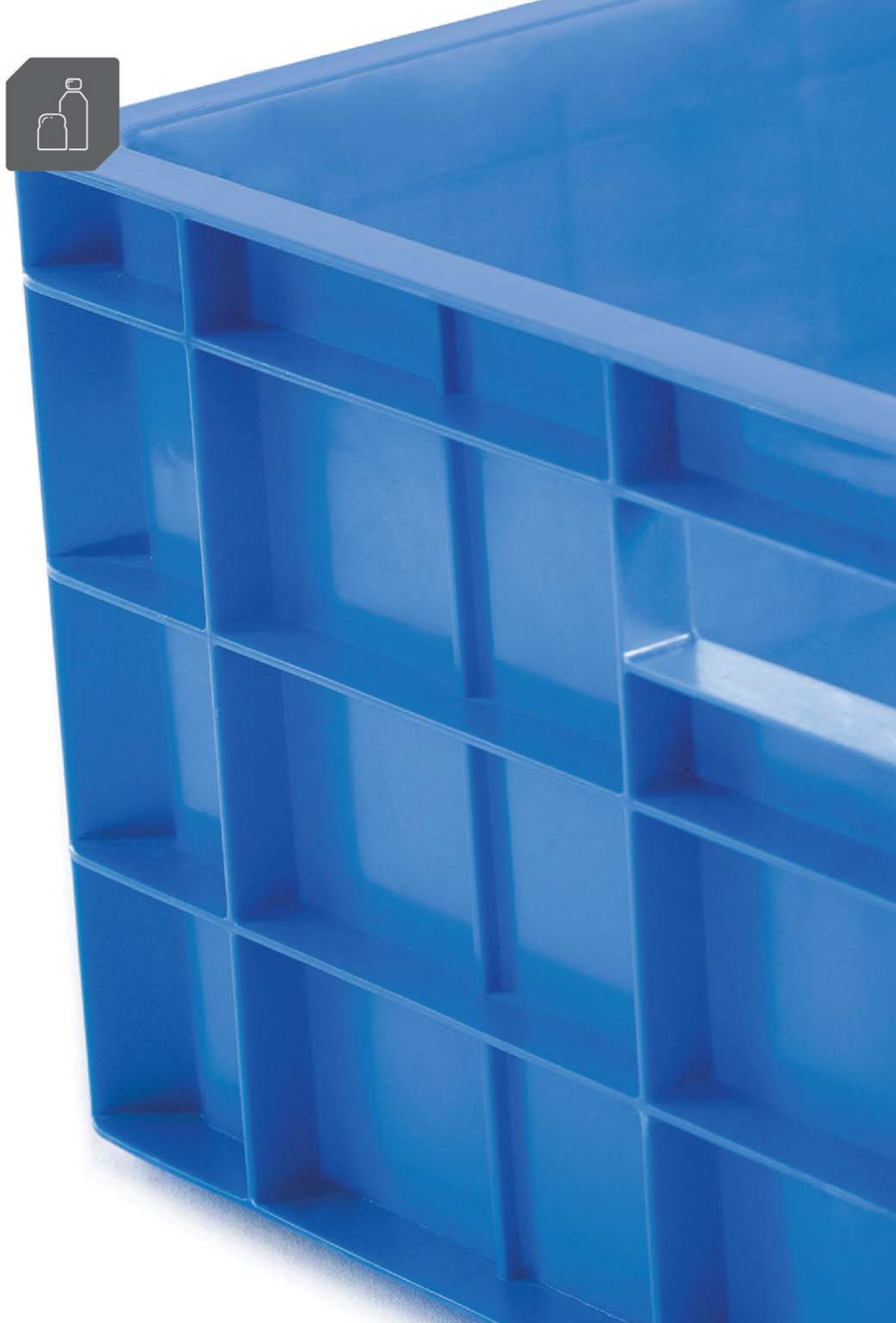

Crate Weight (Kg)

4.2

Crate Capacity (L)

98

Stackable

✓

Nestable

✗

Crate Load (Max) (Kg)

25

Stacking Units (Max)

6

Material

Polypropylene



CRATE  
BC180

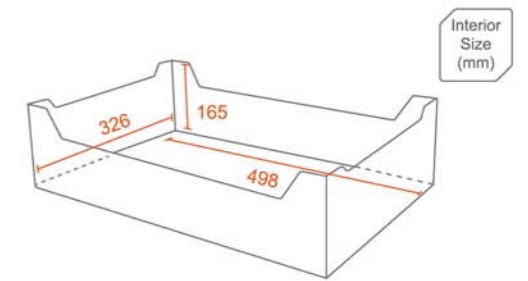
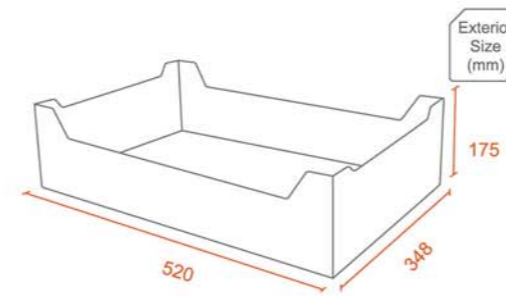

Crate Weight (Kg)

1.4

Crate Capacity (bottles)

48

Stackable

✓

Nestable

✗

Crate Load (Max) (Kg)

25

Stacking Units (Max)

6

Material

Polyethylene



CRATE  
BC200

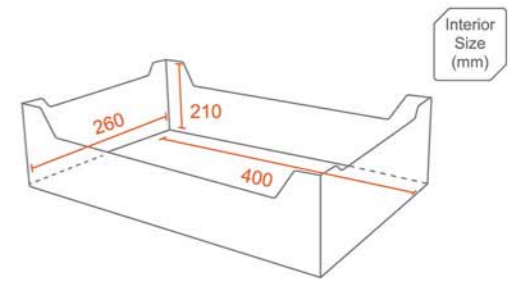
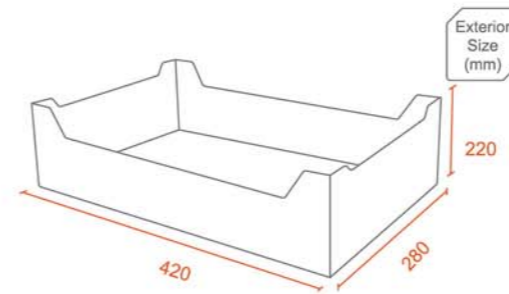

Crate Weight (Kg)

1.3

Crate Capacity (bottles)

24

Stackable

✓

Nestable

✗

Crate Load (Max) (Kg)

25

Stacking Units (Max)

6

Material

Polyethylene

CRATE  
BC250

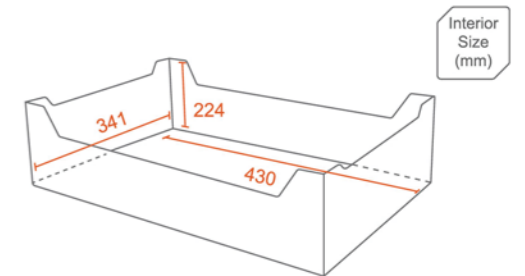
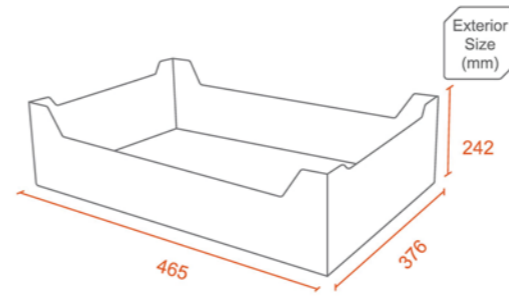

Crate Weight (Kg)

2

Crate Capacity (bottles)

30

Stackable

✓

Nestable

✗

Crate Load (Max) (Kg)

25

Stacking Units (Max)

6

Material

Polyethylene

CRATE  
BC300

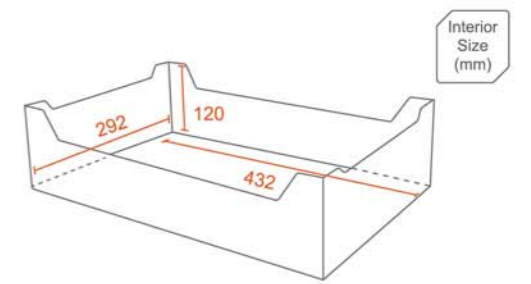
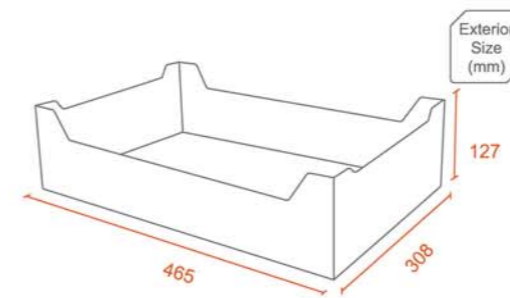
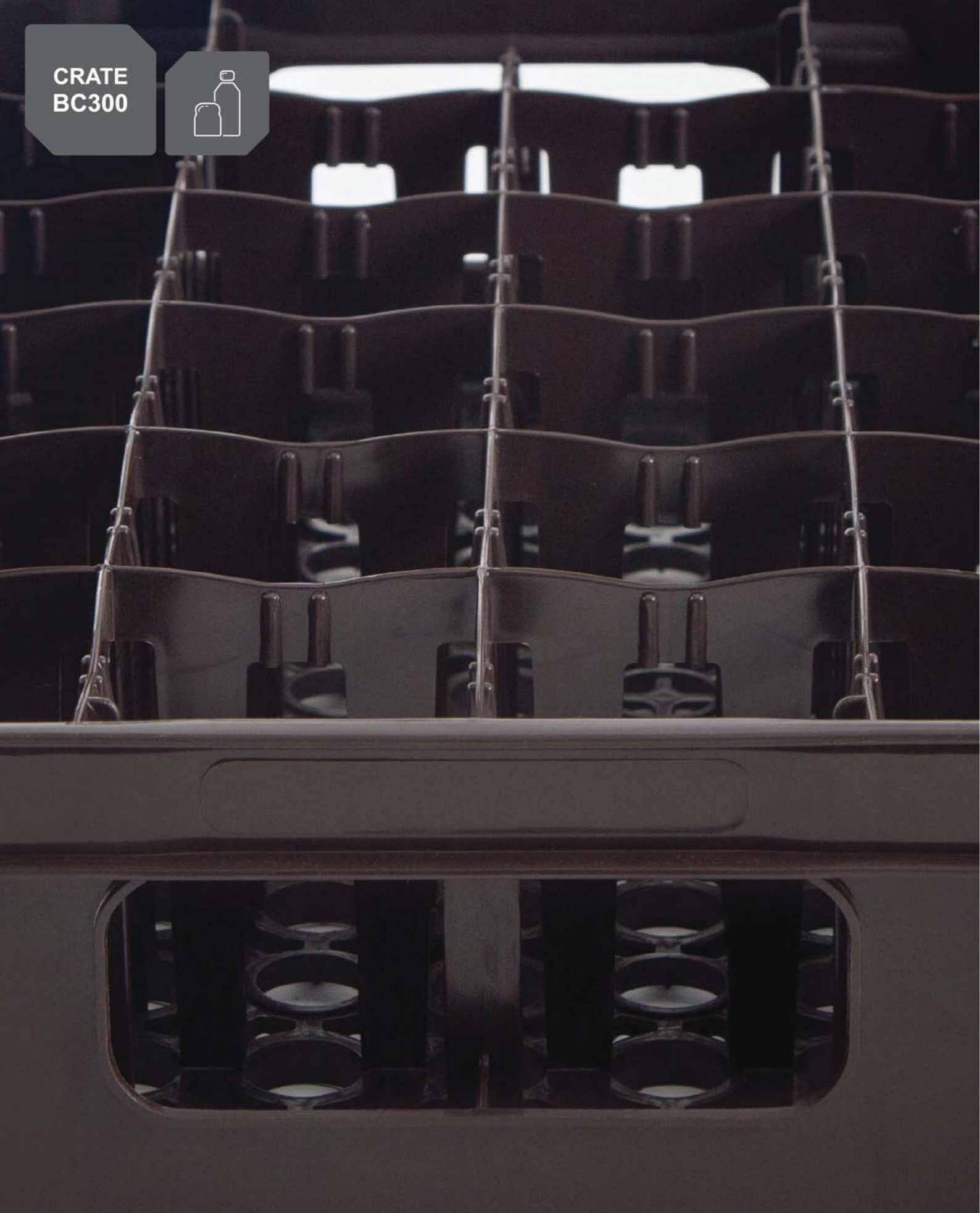

Crate Weight (Kg)

1.25

Crate Capacity (bottles)

24

Stackable

✓

Nestable

✗

Crate Load (Max) (Kg)

20

Stacking Units (Max)

6

Material

Polyethylene

CRATE  
BC375

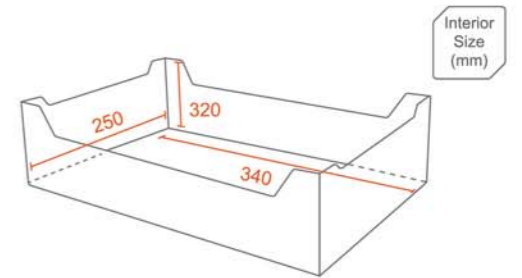
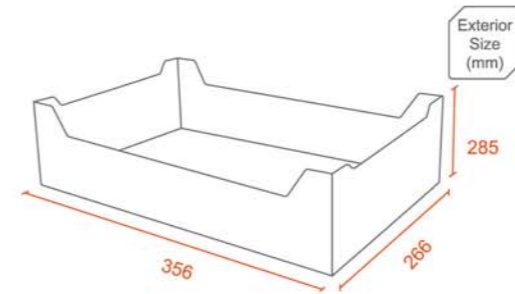
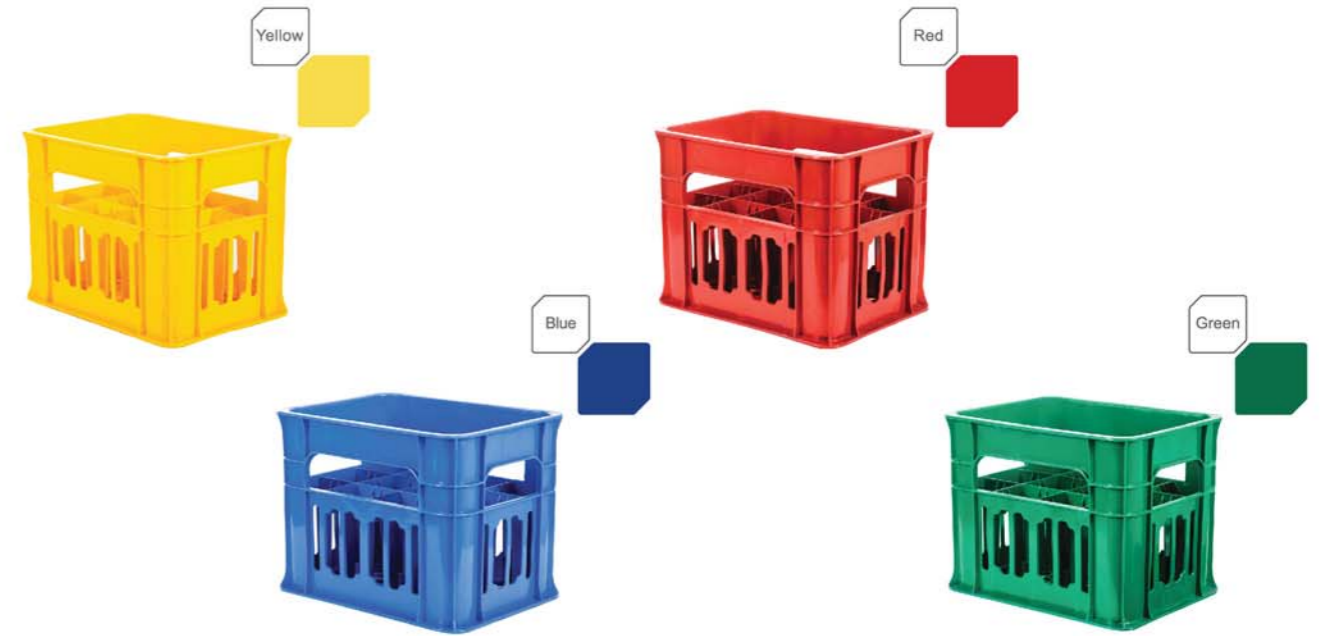

Crate Weight (Kg)	1.4	Crate Capacity (bottle)	12	Stackable	✓	Nestable	✗
Crate Load (Max) (Kg)	20	Stacking Units (Max)	6	Material	Polyethylene		

CRATE  
BC500



Red



Brown

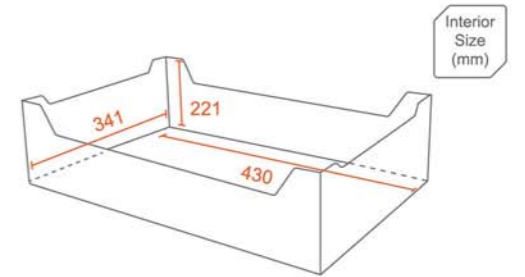
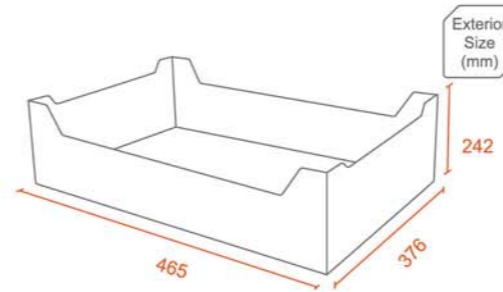

Crate Weight (Kg)

1.8

Crate Capacity (bottles)

20

Stackable

✓

Nestable

✗

Crate Load (Max) (Kg)

20

Stacking Units (Max)

6

Material

Polyethylene

CRATE  
BC625

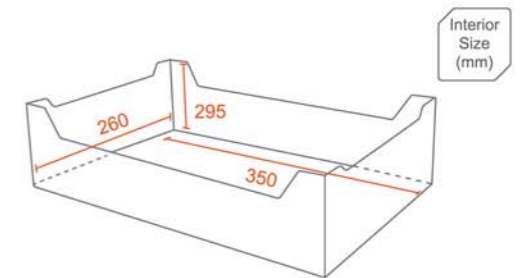
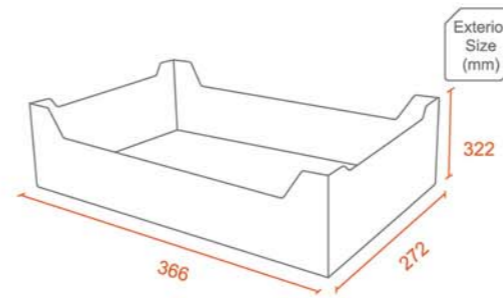
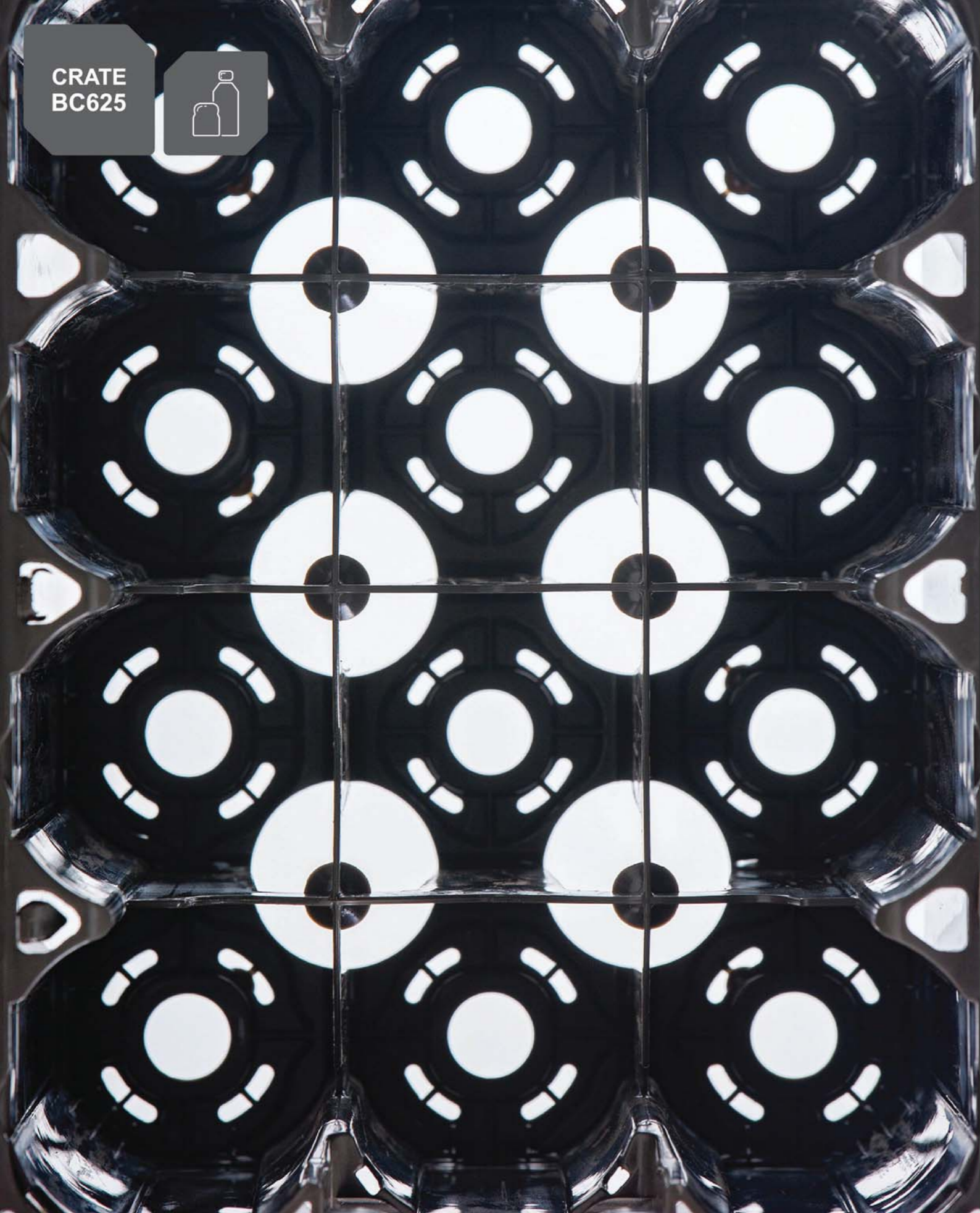

Crate Weight (Kg)

1.68

Crate Capacity (bottles)

12

Stackable

✓

Nestable

✗

Crate Load (Max) (Kg)

20

Stacking Units (Max)

5

Material

Polyethylene

CRATE  
BC750-1



Blue

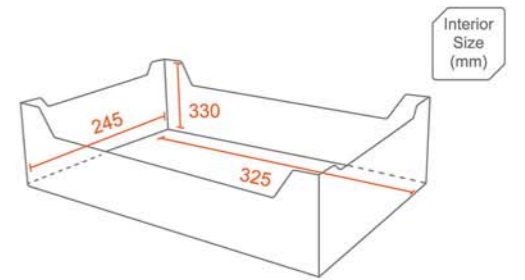
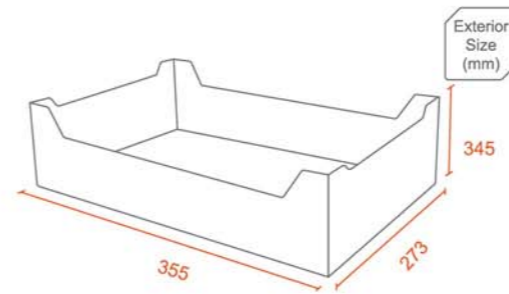

Crate Weight (Kg)

1.74

Crate Capacity (bottles)

12

Stackable

✓

Nestable

✗

Crate Load (Max) (Kg)

20

Stacking Units (Max)

5

Material

Polyethylene

CRATE  
BC750-2

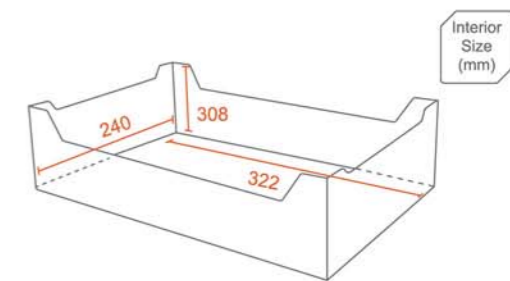
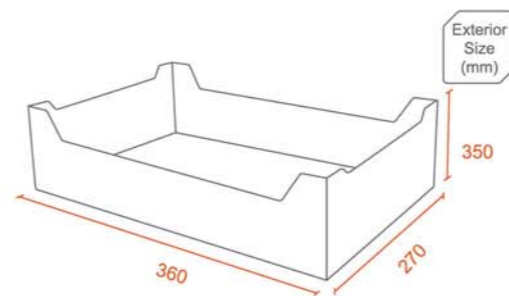

Crate Weight (Kg)

1.4

Crate Capacity (bottles)

12

Stackable

✓

Nestable

✗

Crate Load (Max) (Kg)

20

Stacking Units (Max)

5

Material

Polyethylene



CRATE  
BC750-3

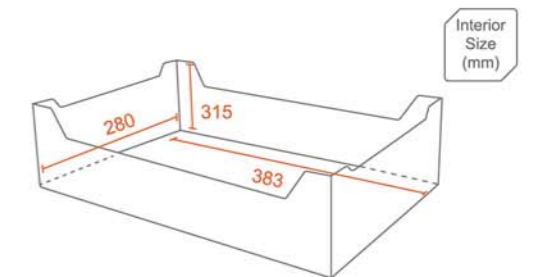
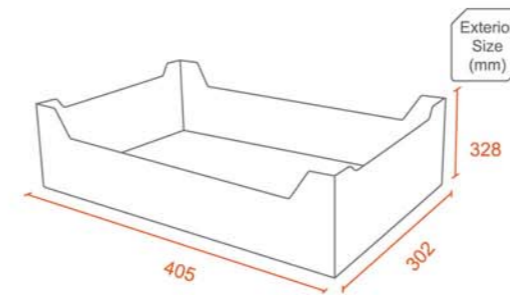
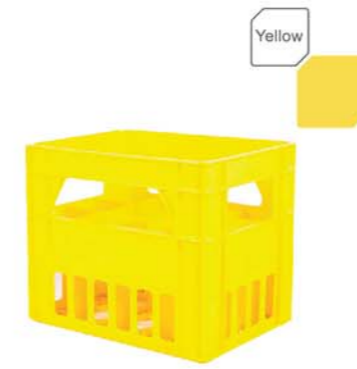

Crate Weight (Kg)

1.7

Crate Capacity (bottles)

12

Stackable

✓

Nestable

✗

Crate Load (Max) (Kg)

20

Stacking Units (Max)

5

Material

Polyethylene



GLASS  
CRATE

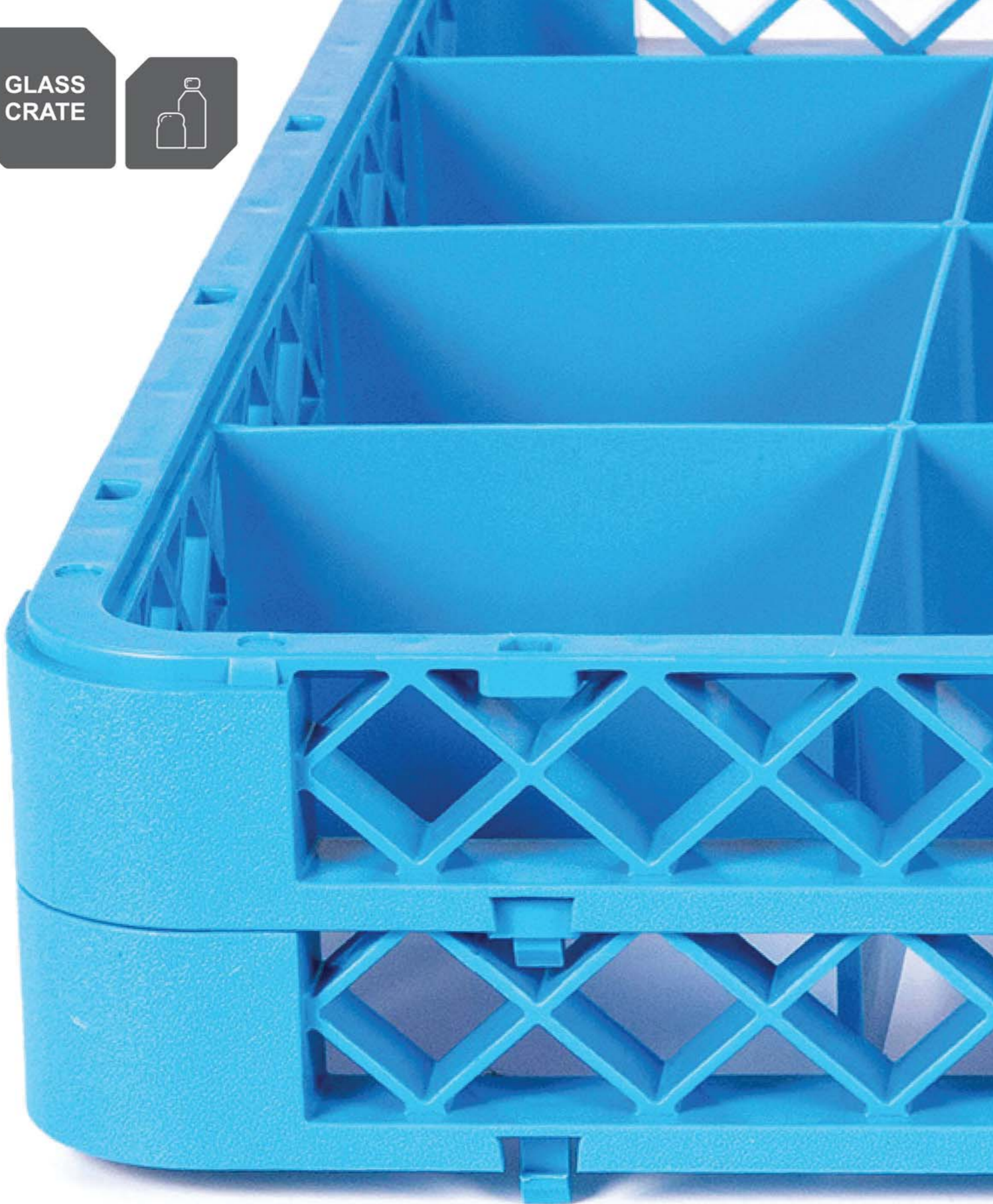
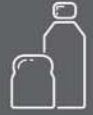

## GLASS CRATE JW16



Blue

Exterior  
Size  
(mm)

500x500x100

Cavity  
Size  
(mm)

112x112x82

Crate  
Weight  
(Kg)

1.9

Crate  
Capacity  
(glasses)

16

Stackable



Nestable



Material

Polypropylene

## GLASS CRATE JW162

EXTENDER FOR GLASS CRATE JW16

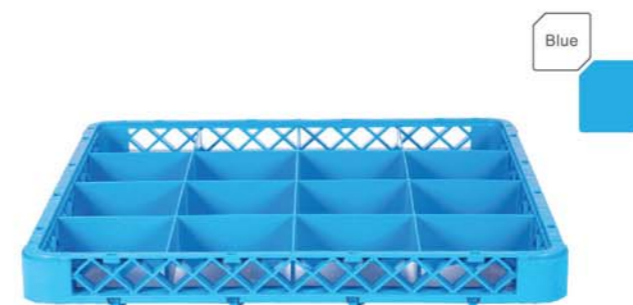

Blue

Exterior  
Size  
(mm)

500x500x45

Cavity  
Size  
(mm)

112x112x40

Crate  
Weight  
(Kg)

0.7

Crate  
Capacity  
(glasses)

16

Stackable



Nestable



Material

Polypropylene

GLASS  
CRATE

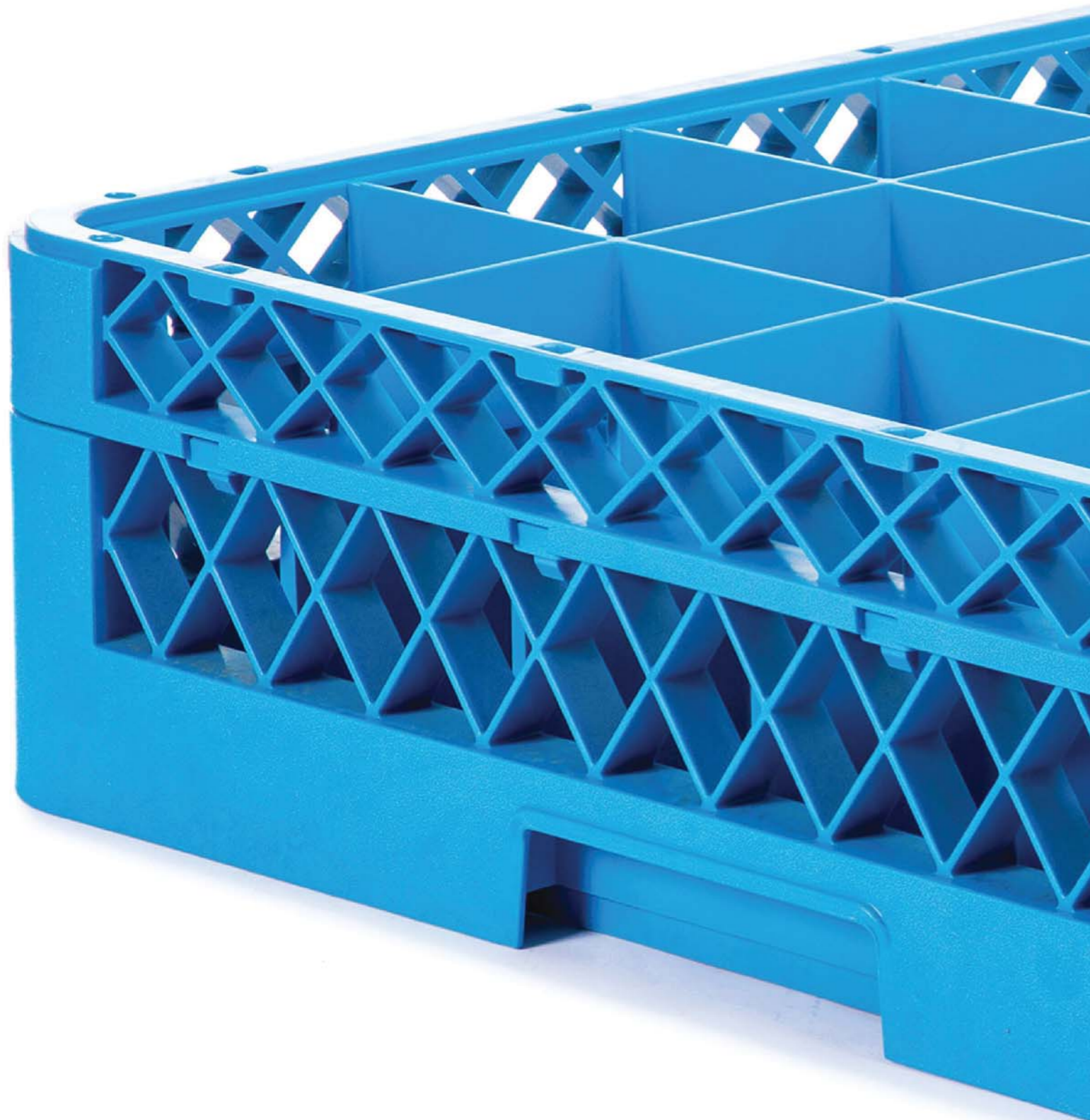

## GLASS CRATE JW25



Exterior Size (mm)  
500x500x100

Cavity Size (mm)  
88x88x82

Crate Weight (Kg)  
2.1

Crate Capacity (glasses)  
25

Stackable  
✓

Nestable  
✗

Material  
Polypropylene

## GLASS CRATE JW252

EXTENDER FOR GLASS CRATE JW25



Exterior Size (mm)  
500x500x45

Cavity Size (mm)  
88x88x40

Crate Weight (Kg)  
0.75

Crate Capacity (glasses)  
25

Stackable  
✓

Nestable  
✗

Material  
Polypropylene

GLASS  
CRATE



## GLASS CRATE JW36



Exterior Size (mm)  
500x500x100

Cavity Size (mm)  
73x73x82

Crate Weight (Kg)  
2.25

Crate Capacity (glasses)  
36

Stackable  
✓

Nestable  
✗

Material  
Polypropylene

## GLASS CRATE JW362

EXTENDER FOR GLASS CRATE JW36



Exterior Size (mm)  
500x500x45

Cavity Size (mm)  
73x73x40

Crate Weight (Kg)  
0.8

Crate Capacity (glasses)  
36

Stackable  
✓

Nestable  
✗

Material  
Polypropylene

# LOGISTICS AND WAREHOUSE



**PNX 0806L**



Exterior Size (mm)	800x600x140
Pallet Weight (Kg)	3.35
Static Load (Kg)	500
Dynamic Load (Kg)	250
Material	Polyethylene

**PNX1208L**



Exterior Size (mm)	1200x800x140
Pallet Weight (Kg)	5.96
Static Load (T)	1
Dynamic Load (T)	0.5
Material	Polyethylene

**PNX 1210 D4**



Exterior Size (mm)	1200x1000x150
Pallet Weight (+/- 1Kg)	20
Dynamic Load (T)	1
Static Load (T)	3
Racking Load (T)	0.5
4 Way Fork Lift Entry	
Material	Polyethylene

## PNX 1111D-B



## PNX 1208 WT WITH 8 STEEL TUBES



## PNX 1208 WT

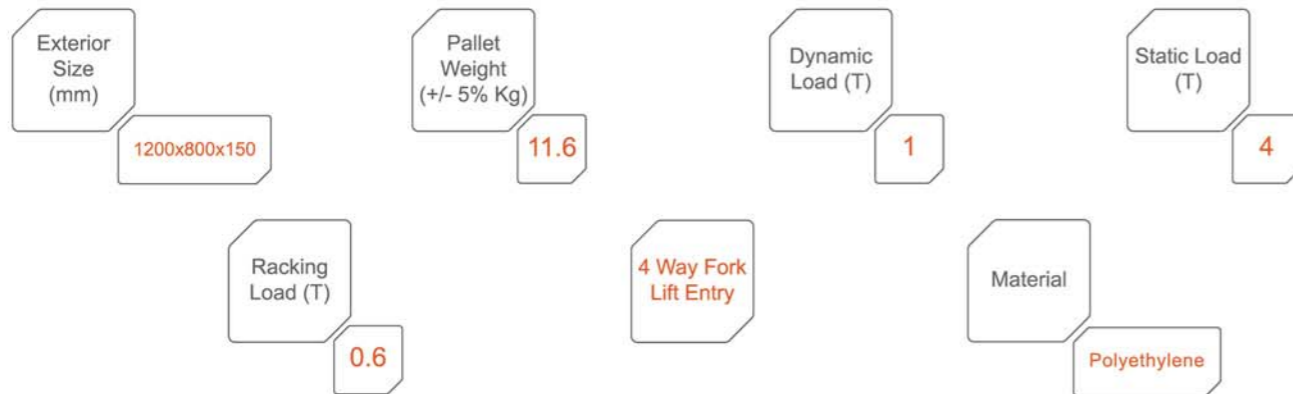

## PNX 1210 CB-D1

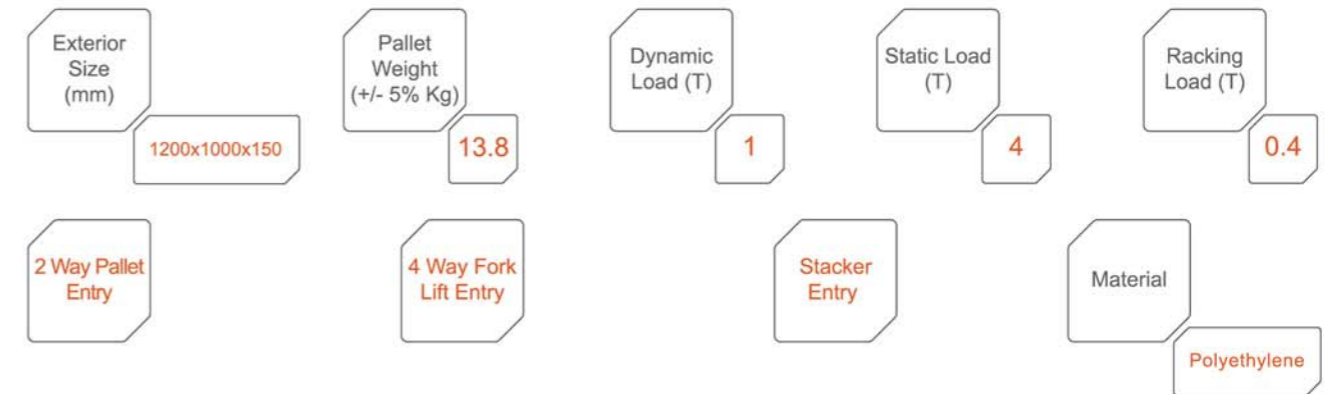



## PNX 1212 CB-B

WITH 10 STEEL TUBES

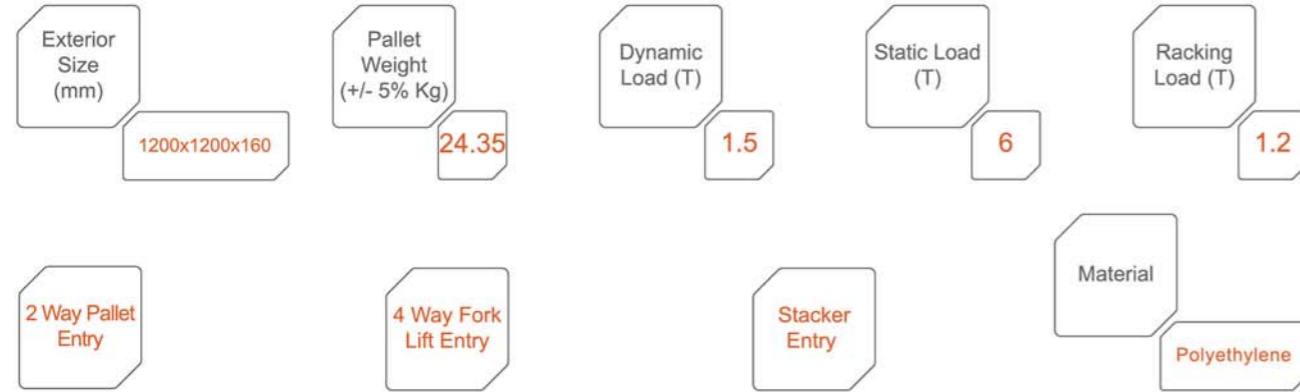

## PNX 1210 CB-D1

WITH 8 STEEL TUBES

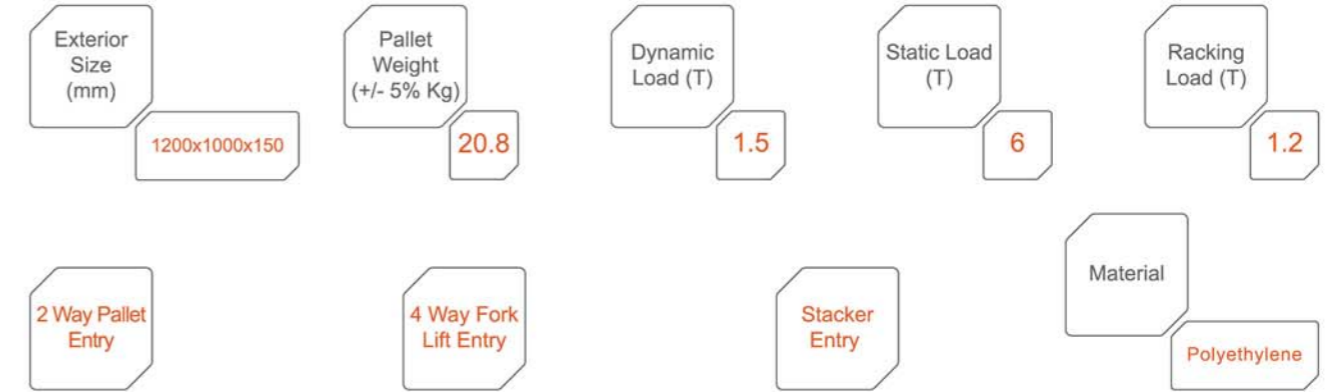

## PNX SNP 1210-52

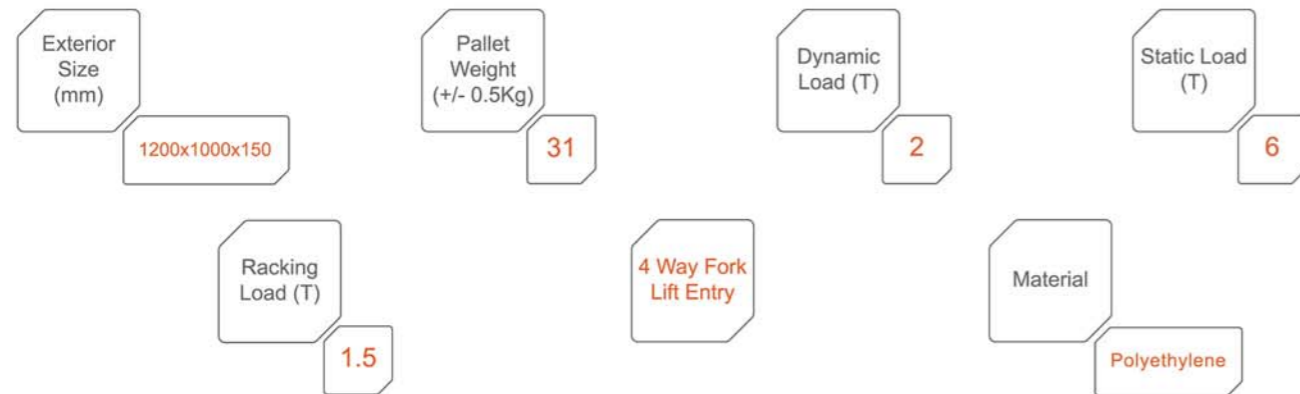

## PNX 1212 CB-B

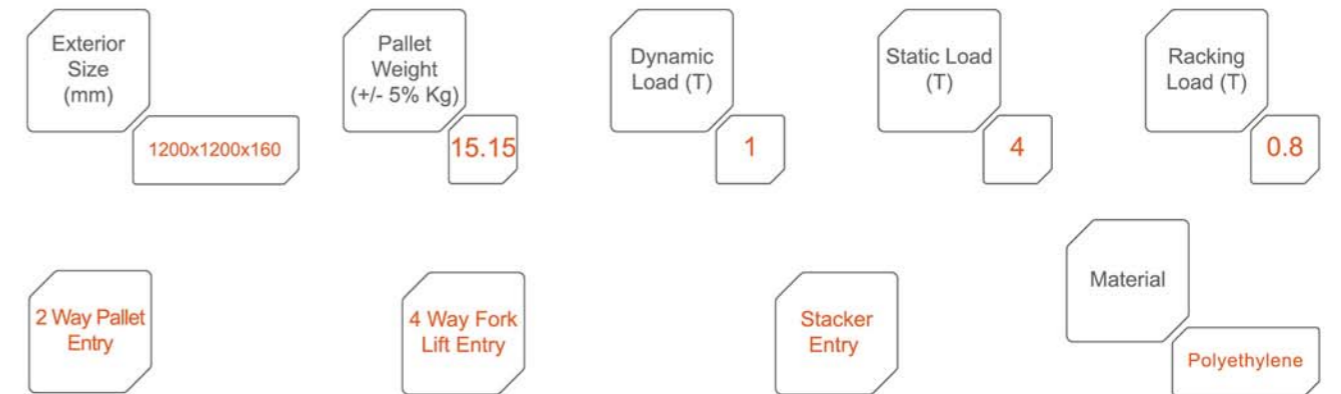

## PNX 1210 PC-A

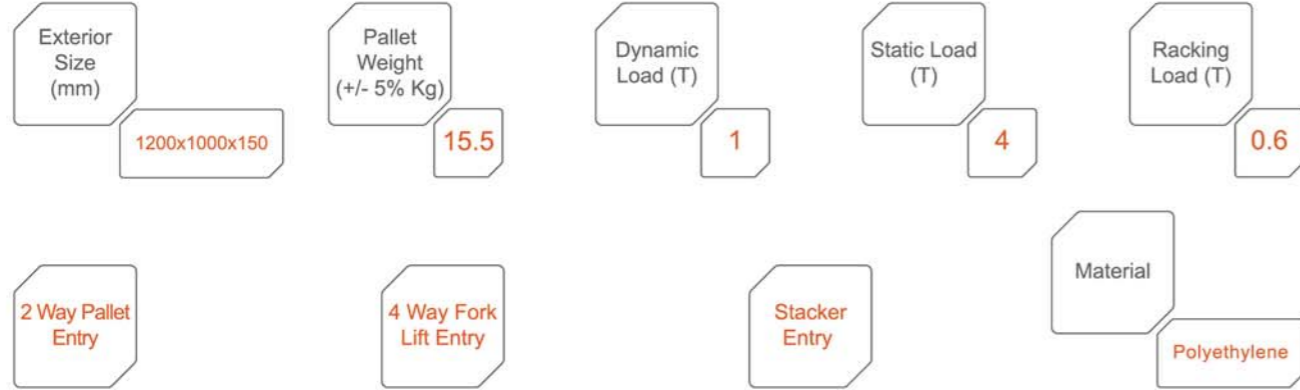

## PNX 1210 WC-A

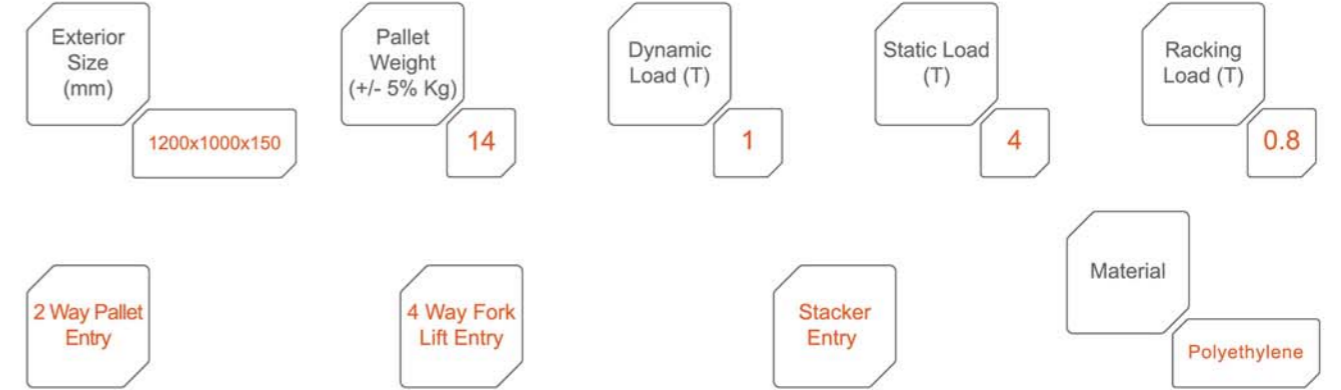

## PNX 1210 PC-A WITH 8 STEEL TUBES

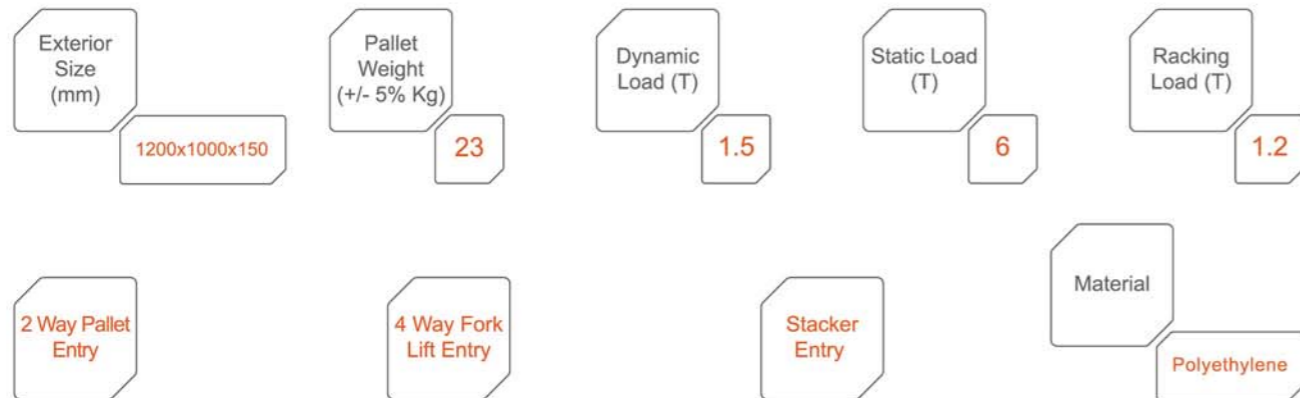

## PNX 1210 WC-A WITH 8 STEEL TUBES

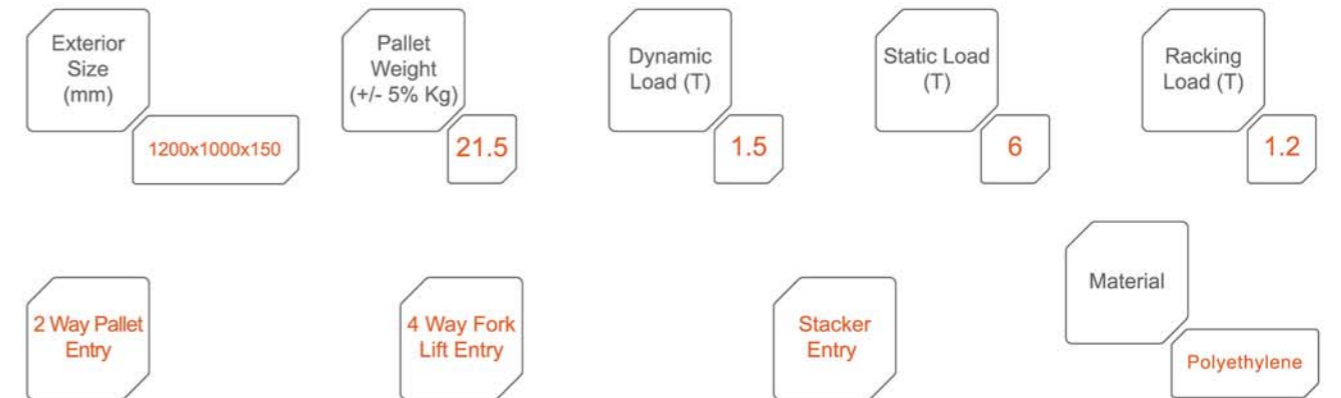

APPAREL  
CRATE

WITH  
LID

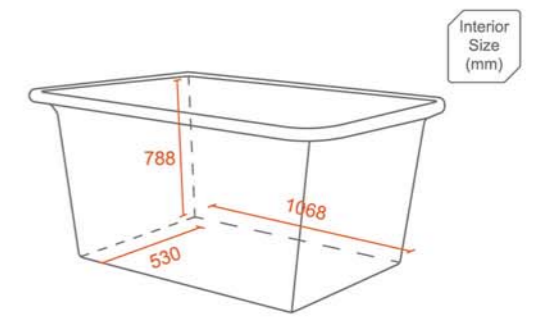
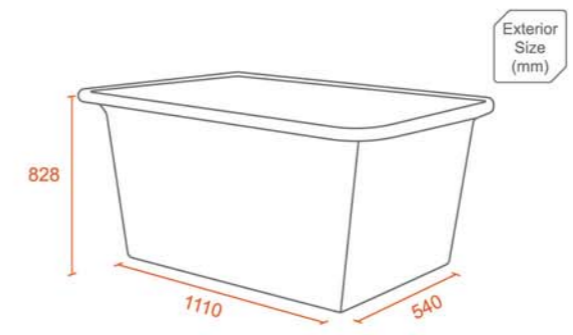

Crate Weight  
(with lid)  
(Kg)

15.2

Crate Weight  
(without lid)  
(Kg)

11.6

Crate Capacity  
(L)

325

Material

Polyethylene

# ADDITIONAL SOLUTIONS



CRATE  
TOOL  
BOX

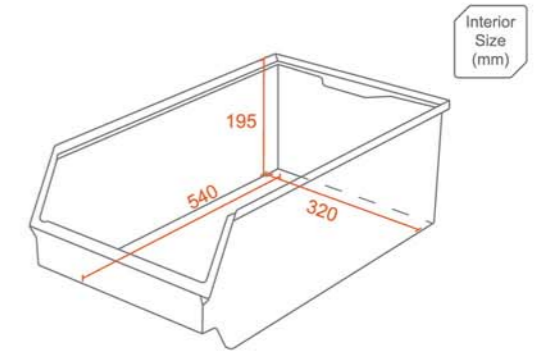
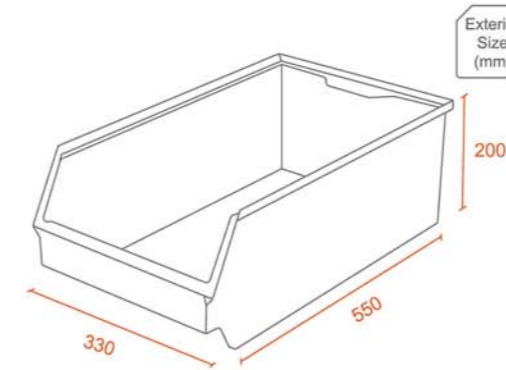

Crate Weight (Kg)

1.57

Crate Capacity (L)

34

Material

Polypropylene



### 360L - HEAVY DUTY



Exterior Size (mm)	837x710x1115	Weight (+/- 3% Kg)	22
Crate Capacity (L)	360	Material	Polyethylene

### 660L - HEAVY DUTY



Exterior Size (mm)	1375x780x1220	Weight (+/- 3% Kg)	42.7
Useful Load (Kg)	270	Material	Polyethylene
Crate Capacity (L)	660		

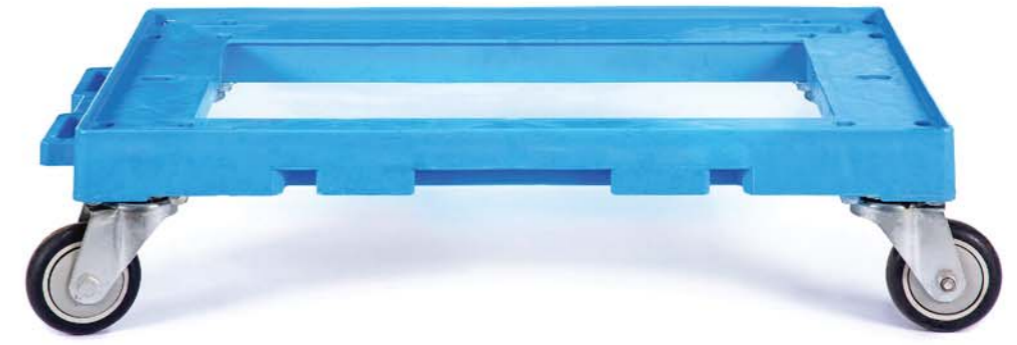

Exterior Size (mm)  
610x410x145

Capacity (L)  
300  
Compatible with 600x400mm or Less Crate Models

Weight (Kg)  
3.5

Material  
Polypropylene

# #DesignedForLife

## Contact Us

### Factory:

**Phoenix Industries Ltd**  
Industrial Zone East,  
Makandura, Gonawila,  
Sri Lanka.

Tel: +94 (0) 777 889 999

### Flagship Stores:

**Phoenix Showroom - Welisara**  
445 Negombo Road, Welisara,  
Sri Lanka.

Tel: +94 (0) 773 951 241 / 773 124 745

**Phoenix Showroom - Panadura**  
12 Mahanama Road, Panadura,  
Sri Lanka.

Tel: +94 (0) 772 689 474 / 382 224 051

[www.phoenix.lk](http://www.phoenix.lk)



# DESIGNED FOR LIFE